

**Ministry of Higher Education  
And Scientific Research  
University of Diyala  
College of Engineering**



# **NUMERICAL STUDY OF CORRUGATED STEEL PLATE SHEAR WALLS**

A Thesis Submitted to Council of College of Engineering,  
University of Diyala in Partial Fulfillment of the Requirements  
for the Degree of Master of Science in Civil Engineering

**By**

**Hayder Fadhil Abbood Al-Tameemi**

(B.Sc. in Civil Engineering, 2014)

**Supervised by**

**Prof. Dr. Amer M. Ibrahim**

**Dr. Mohammed Sh. Mahmood**

January, 2019

IRAQ

Jumada al-awwal, 1440

# 6

رَبِّ أَوْزِعْنِي أَنْ أَشْكُرَ نِعْمَتَكَ الَّتِي أَنْعَمْتَ عَلَيَّ وَعَلَى  
وَالِدَيَّ وَأَنْ أَعْمَلَ صَالِحًا تَرْضَاهُ وَأَدْخِلْنِي بِرَحْمَتِكَ فِي  
عِبَادِكَ الصَّالِحِينَ

صَدَقَ اللَّهُ الْعَظِيمُ

سورة النمل  
آية (١٩)

## COMMITTEE DECISION

We certify that we have read the thesis entitled (**Numerical study of Corrugated Steel Plate Shear Walls**) and we have examined the student (**Hayder Fadhil Abbood**) in its content and what is related with it, and in our opinion, it is adequate as a thesis for the degree of Master of Science in Civil Engineering.

**Examination Committee**

**Signature**

Prof. Dr. Amer M. Ibrahim (Supervisor).....*Prof. Dr. Amer*

Dr. Mohammed Sh. Mahmood (co-Supervisor).....*MS*

Assist. Prof. Dr. Ali Laftah Abbas (Member).....*A. Laftah*

Assist. Prof. Dr. Ahmed A. Mansoor (Member).....*A.A. Mansoor*

Prof. Dr. Khalid B. Najim (Chairman).....*K.B. Najim*

Prof. Dr. Hafeth Ibrahim Naji .....*H.I. Naji* (Head of Department)

The thesis was ratified at the Council of College of Engineering /  
University of Diyala.

Signature.....*AbdulMonem A. Karim*

Name: Prof. Dr. AbdulMonem Abbas Karim

Dean of College of Engineering / University of Diyala

Date: *24/2/2019*

## Dedication

*I dedicate this work to my parents without whom being around, this study would have remained just a thread of an idea. It is also dedicated to my brother and sisters for their support and assistance*

## ACKNOWLEDGMENTS

*All Praise is due to Allah, before everything.*

*I would like to express my deep thanks and gratitude to my supervisors Prof. Dr. Amer M. Ibrahim and Dr. Mohammed Sh. Mahmood for their supervision, encouragement, and efforts throughout the stages of this study. I am also grateful to the College of engineering, especially, Civil Engineering Department and the Seminars committee. Finally, inexpressible are paid to those who help me accomplishing this work.*

## **Abstract**

# **Numerical study of Corrugated Steel Plate Shear Walls**

By

Hayder Fadhil Abbood

Supervisors

Prof. Amer M. Ibrahim, Ph.D.    Dr. Mohammed Sh. Mahmood, Ph.D.

A shear wall is a structural element that is used to resist the lateral loads resulting from winds, earthquakes and gravity loads. The corrugated steel shear walls are one type of this system. It consists mainly of the steel frame (two beams and columns) and infill corrugated steel plate. They have several advantages including ductility, strength, and energy dissipation let alone the lightweight.

This study uses the finite element method to build and analyses the models of the corrugated steel plate shear walls. The model outcomes validate the available experimental data in the literature and they provide reliable results under the horizontal cyclic loading. The numerical models are simulated using Abaqus/CAE (2017).

The research seeks to investigate and evaluate the performance of the corrugated steel plate shear wall through a parametric study. The performance is assessed by the initial stiffness, ductility ratio, strength and energy dissipation. The effect of the angles and directions of the corrugation of the plate, the length of the horizontal and the inclined side of the corrugation of the plate, the thickness of the plate, the aspect ratio of the plate, and the presence of an opening in the plate are all investigated and evaluated.

The results show that the increase of the corrugation angle leads to decreasing the performance of the shear wall. The angles  $30^\circ$  and  $20^\circ$  in vertical and horizontal corrugations respectively provide the optimal performance required. 100mm and 50mm are the lengths of the horizontal and the inclined sides of the corrugations respectively which can afford the best performance in ultimate strength by 7%, 11%, and energy dissipation 5.5%, 6% and it gives acceptable performance in terms of initial stiffness and ductility ratio.

The increasing of the thickness of the plate leads to increasing the performance of the corrugated steel plate shear wall by 26% in dissipated energy and 22% in ultimate strength. Knowing that thickness has a clear impact on the ductility.

The results show that increasing the height of the corrugated plate leads to lowering the performance while the increasing the length of the corrugated plate with a suitable height that leads to increasing the performance where the aspect 1.6 gives the better performance.

The presence of an opening in the plate leads to reducing in the performance of the corrugated plate with increasing the percentage of opening and the circular opening gives better performance from the square opening in the ultimate strength and energy dissipation by 4%, 3%. Also, the results reveal that when the two directions of the corrugation of the plate are compared, the vertical corrugation gives a better performance than that given by the horizontal corrugation.

## Table of Contents

Subject	Page No.
Dedication	I
Acknowledgment	II
Abstract	III
Table of Contents	V
A List of Figures	IX
A List of Tables	XIV
A List of Symbols	XVI
A List of Abbreviations	XVIII
<b>Chapter One</b>	
<b>Introduction</b>	
1.1 General	<b>1</b>
1.2 Behavior of corrugated steel plate shear wall	<b>4</b>
1.2.1 Buckling type	<b>4</b>
1.2.1.1 The Local buckling	<b>4</b>
1.2.1.2 The global buckling	<b>5</b>
1.2.1.3 The interactive buckling	<b>6</b>
1.3 Aim and objectives of the study	<b>7</b>
1.4 Scope of study	<b>7</b>
1.5 Methodology	<b>7</b>
1.6 Outline of Thesis	<b>8</b>
<b>Chapter Two</b>	
<b>Literature Review</b>	
2.1 General	<b>9</b>
2.2 corrugated steel plate shear walls	<b>9</b>



2.3 Summary and Conclusions	<b>23</b>
<b>Chapter Three</b>	
<b>Finite Element Modeling and Validations</b>	
3.1 General	<b>25</b>
3.2 Finite Element Representation	<b>25</b>
3.2.1 Steel materials	<b>26</b>
3.2.2 Nonlinear Solution Techniques	<b>27</b>
3.2.3 Shell element (S4R)	<b>28</b>
3.2.4 Materials modeling	<b>28</b>
3.2.5 Tie constraint	<b>29</b>
3.2.6 Coupling constraints	<b>30</b>
3.2.7 The Contact Interactions	<b>31</b>
3.3 Validating the Finite Element Model	<b>31</b>
3.3.1 Emami programmers	<b>31</b>
3.3.2 Hosseinzadeh programmers	<b>32</b>
3.4 Boundary Conditions	<b>34</b>
3.5 Load case	<b>35</b>
3.6 Mesh sensitivity	<b>36</b>
3.7 Results validation	<b>37</b>
3.8 Formation and analysis the model using Abaqus	<b>42</b>
<b>Chapter Four</b>	
<b>Results and discussion</b>	
4.1 General	<b>44</b>
4.2 Case Study Results	<b>44</b>
4.3 Geometric	<b>45</b>
4.3.1 Angle of corrugation	<b>46</b>
A- Ultimate strength	<b>46</b>
B- Initial stiffness	<b>48</b>

C- Ductility ratio	<b>51</b>
D- Energy dissipation	<b>53</b>
E- Correlation between variables	<b>55</b>
4.3.2 The horizontal side	<b>60</b>
A- Ultimate strength	<b>60</b>
B- Initial stiffness	<b>62</b>
C- Ductility ratio	<b>64</b>
D- Energy dissipation	<b>66</b>
E- Correlation between variables	<b>67</b>
4.3.3 The inclined side	<b>71</b>
A- Ultimate strength	<b>71</b>
B- Initial stiffness	<b>73</b>
C- Ductility ratio	<b>75</b>
D- Energy dissipation	<b>76</b>
E- Correlation between variables	<b>78</b>
4.4 Aspect ratio of the corrugated plate.	<b>81</b>
A- Ultimate strength	<b>81</b>
B- Initial stiffness	<b>83</b>
C- Ductility ratio	<b>84</b>
D- Energy dissipation	<b>85</b>
E- Correlation between variables	<b>87</b>
4.5 Opening in the corrugated plate.	<b>89</b>
A- Ultimate strength	<b>89</b>
B- Initial stiffness	<b>91</b>
C- Ductility ratio	<b>92</b>
D- Energy dissipation	<b>93</b>
E- Correlation between variables	<b>95</b>

<b>Chapter five</b>	
<b>Conclusions and Recommendations</b>	
<b>5.1 Conclusions</b>	<b>97</b>
<b>5.2 Recommendations</b>	<b>99</b>
<b>References</b>	<b>100</b>

## A List of Figures

Figure No.	Figure title	Page No.
1-1	<b>Location and shape of the steel plate and RC shear walls.</b>	<b>1</b>
1-2	<b>The CSPSW in the formation and the geometric shape.</b>	<b>3</b>
1-3	<b>Details of the geometric shape of CSPSW.</b>	<b>3</b>
1-4	<b>The effect of the later load on the CSPSW.</b>	<b>4</b>
1-5	<b>Local buckling in the corrugated plate (Yi et al., 2008).</b>	<b>5</b>
1-6	<b>Global buckling in the corrugated plate (Yi et al., 2008).</b>	<b>6</b>
1-7	<b>Interactive buckling in the corrugated plate (Yi et al., 2008).</b>	<b>6</b>
2-1	<b>The dimension and failure mode of the specimen (Mo and Perng, 2000).</b>	<b>9</b>
2-2	<b>Details of the specimen test (Berman and Bruneau, 2005).</b>	<b>10</b>
2-3	<b>The FE model of the test (Gholizadeh and Yadollahi, 2011).</b>	<b>11</b>
2-4	<b>Details of the specimen test (Emami et al., 2013).</b>	<b>12</b>
2-5	<b>Corrugated steel shear wall specimen (Vigh et al., 2013).</b>	<b>13</b>
2-6	<b>Details and FE model of the specimen test (Farzampour and Laman, 2015).</b>	<b>14</b>
2-7	<b>Geometric and FE model of the specimen test (Tong and Guo, 2015).</b>	<b>15</b>
2-8	<b>Details and FE model of specimen test (Bahrebar et al., 2016b).</b>	<b>15</b>
2-9	<b>Details and FE model of specimen test (Bahrebar et al., 2016b).</b>	<b>16</b>
2-10	<b>Details of CSPSW specimen test (Hosseinzadeh, Emami and Mofid, 2017).</b>	<b>17</b>
2-11	<b>The failure mode for vertical and horizontal specimens (Shon et al., 2017).</b>	<b>17</b>
2-12	<b>The corrugated shear wall and FE model (Hosseinzadeh et al., 2017b).</b>	<b>18</b>
2-13	<b>The FE model of the corrugated shear wall and corrugation shape of a plate (Zhao et al., 2017).</b>	<b>19</b>
2-14	<b>Details of the specimen and the FE model of the corrugated shear wall (Tong and Guo, 2018).</b>	<b>20</b>

2-15	<b>Details of the specimen and corrugation plate (Farzampour et al., 2018).</b>	<b>21</b>
2-16	<b>Details and failure mode of the specimen test (Cao and Huang, 2018).</b>	<b>22</b>
2-17	<b>Details of specimen and FE model of double corrugated plate shear wall (Tong et al., 2018).</b>	<b>23</b>
3-1	<b>An area crudely meshed with linear triangles (Akin, 2010).</b>	<b>25</b>
3-2	<b>Stress-strain behavior of steel at small strains (Abaqus, 2016).</b>	<b>26</b>
3-3	<b>Stress-strain behavior of steel material (Abaqus, 2016).</b>	<b>26</b>
3-4	<b>The node freedom and the location of nodes for shell element(Abaqus, 2016).</b>	<b>28</b>
3-5	<b>Tie constrains for shell element (Abaqus, 2016) .</b>	<b>29</b>
3-6	<b>Tie constrain in the FE models.</b>	<b>30</b>
3-7	<b>The kinematic coupling constraints (Abaqus, 2016).</b>	<b>30</b>
3-8	<b>The kinematic coupling constraints in FE models.</b>	<b>30</b>
3-9	<b>Contact Interactions of the plate in FE models.</b>	<b>31</b>
3-10	<b>Details of Emami specimens (Emami et al., 2013).</b>	<b>32</b>
3-11	<b>Details of Hosseinzadeh specimens (Hosseinzadeh, Emami and Mofid, 2017).</b>	<b>33</b>
3-12	<b>The FE model and the geometric shape of Emami specimens.</b>	<b>33</b>
3-13	<b>The FE model and the geometric shape of Hosseinzadeh specimen.</b>	<b>34</b>
3-14	<b>Boundary conditions of the FE models.</b>	<b>35</b>
3-15	<b>Load case in the FE models.</b>	<b>35</b>
3-16	<b>History loading of Emami and Hosseinzadeh based on the AC154 protocol.</b>	<b>36</b>
3-17	<b>Ultimate strength values of model for the different mesh sizes.</b>	<b>37</b>
3-18	<b>(A) Deflected shape of Emami specimen (30v°), (B) failure mode of FE model.</b>	<b>37</b>
3-19	<b>(A) Deflected shape of Emami specimen (30h°), (B) failure mode of FE model.</b>	<b>37</b>
3-20	<b>(A) Deflected shape of Hosseinzadeh specimen (30°), (B) failure mode of FE model.</b>	<b>38</b>

3-21	<b>(A) Deflected shape of Hosseinzadeh specimen (45°), (B) failure mode of FE model.</b>	<b>38</b>
3-22	<b>(A) Deflected shape of Hosseinzadeh specimen (60°), (B) failure mode of FE model.</b>	<b>38</b>
3-23	<b>Envelope curves for experimental and numerical Emami specimen (30°v).</b>	<b>39</b>
3-24	<b>Envelope curves for experimental and numerical Emami specimen (30°h).</b>	<b>40</b>
3-25	<b>Envelope curves for experimental and numerical Hosseinzadeh specimen (30°).</b>	<b>40</b>
3-26	<b>Envelope curves for experimental and numerical Hosseinzadeh specimen (45°).</b>	<b>40</b>
3-27	<b>Envelope curves for experimental and numerical Hosseinzadeh specimen (60°).</b>	<b>41</b>
3-28	<b>Envelope curves for experimental, numerical and fish plate for Emami specimen (30°v).</b>	<b>41</b>
4-1	<b>Geometric shape of the corrugated plate.</b>	<b>45</b>
4-2	<b>Geometry of plate in case of change the angle of corrugation.</b>	<b>46</b>
4-3	<b>Ultimate strength of CSPSW for angles with thickness 1.25mm.</b>	<b>47</b>
4-4	<b>Ultimate strength of CSPSW for angles with thickness 2mm.</b>	<b>47</b>
4-5	<b>Ultimate strength of CSPSW for angles with thickness 3mm.</b>	<b>48</b>
4-6	<b>Stiffness of CSPSW for angles with thickness 1.25mm.</b>	<b>49</b>
4-7	<b>Stiffness of CSPSW for angles with thickness 2mm.</b>	<b>49</b>
4-8	<b>Stiffness of CSPSW for angles with thickness 3mm.</b>	<b>49</b>
4-9	<b>Ductility concept equal plastic energy.</b>	<b>51</b>
4-10	<b>Ductility ratio of CSPSW for angles with thickness 1.25mm.</b>	<b>52</b>
4-11	<b>Ductility ratio of CSPSW for angles with thickness 2mm.</b>	<b>52</b>
4-12	<b>Ductility ratio of CSPSW for angles with thickness 3mm.</b>	<b>53</b>
4-13	<b>Energy dissipation calculated from hysteresis curve (Sabouri-Ghomi and Sajjadi, 2012).</b>	<b>53</b>
4-14	<b>Energy dissipation of CSPSW for angles with thickness 1.25mm.</b>	<b>54</b>
4-15	<b>Energy dissipation of CSPSW for angles with thickness 2mm.</b>	<b>55</b>
4-16	<b>Energy dissipation of CSPSW for angles with thickness 3mm.</b>	<b>55</b>

4-17	<b>Pearson correlation state from -1 to 1.</b>	<b>56</b>
4-18	<b>Geometry of plate in case of change the horizontal side.</b>	<b>60</b>
4-19	<b>Ultimate strength of CSPSW for horizontal side with thickness 1.25mm.</b>	<b>61</b>
4-20	<b>Ultimate strength of CSPSW for horizontal side with thickness 2mm.</b>	<b>62</b>
4-21	<b>Ultimate strength of CSPSW for horizontal side with thickness 3mm.</b>	<b>62</b>
4-22	<b>Stiffness of CSPSW for horizontal side with thickness 1.25mm.</b>	<b>63</b>
4-23	<b>Stiffness of CSPSW for horizontal side with thickness 2mm.</b>	<b>63</b>
4-24	<b>Stiffness of CSPSW for horizontal side with thickness 3mm.</b>	<b>64</b>
4-25	<b>Ductility ratio of CSPSW for horizontal side with thickness 1.25mm.</b>	<b>65</b>
4-26	<b>Ductility ratio of CSPSW for horizontal side with thickness 2mm.</b>	<b>65</b>
4-27	<b>Ductility ratio of CSPSW for horizontal side with thickness 3mm.</b>	<b>65</b>
4-28	<b>Energy dissipation of CSPSW for horizontal side with thickness 1.25mm.</b>	<b>66</b>
4-29	<b>Energy dissipation of CSPSW for horizontal side with thickness 2mm.</b>	<b>67</b>
4-30	<b>Energy dissipation of CSPSW for horizontal side with thickness 3mm.</b>	<b>67</b>
4-31	<b>Geometry of plate in case of change the inclined side.</b>	<b>71</b>
4-32	<b>Ultimate strength of CSPSW for inclined side with thickness 1.25mm.</b>	<b>72</b>
4-33	<b>Ultimate strength of CSPSW for inclined side with thickness 2mm.</b>	<b>72</b>
4-34	<b>Ultimate strength of CSPSW for inclined side with thickness 3mm.</b>	<b>73</b>
4-35	<b>Stiffness of CSPSW for inclined side with thickness 1.25mm.</b>	<b>74</b>
4-36	<b>Stiffness of CSPSW for inclined side with thickness 2mm.</b>	<b>74</b>
4-37	<b>Stiffness of CSPSW for inclined side with thickness 3mm.</b>	<b>74</b>

4-38	<b>Ductility ratio of CSPSW for inclined side with thickness 1.25mm.</b>	<b>75</b>
4-39	<b>Ductility ratio of CSPSW for inclined side with thickness 2mm.</b>	<b>76</b>
4-40	<b>Ductility ratio of CSPSW for inclined side with thickness 3mm.</b>	<b>76</b>
4-41	<b>Energy dissipation of CSPSW for inclined side with thickness 1.25mm.</b>	<b>77</b>
4-42	<b>Energy dissipation of CSPSW for inclined side with thickness 2mm.</b>	<b>77</b>
4-43	<b>Energy dissipation of CSPSW for inclined side with thickness 3mm.</b>	<b>78</b>
4-44	<b>Details of plate in case of change aspect ratio.</b>	<b>81</b>
4-45	<b>Ultimate strength of CSPSW for increasing the height of plate.</b>	<b>82</b>
4-46	<b>Ultimate strength of CSPSW for increasing the length of plate.</b>	<b>82</b>
4-47	<b>Stiffness of CSPSW for increasing the height of plate.</b>	<b>83</b>
4-48	<b>Stiffness of CSPSW for increasing the length of plate.</b>	<b>84</b>
4-49	<b>Ductility ratio of CSPSW for increasing the height of plate.</b>	<b>85</b>
4-50	<b>Ductility ratio of CSPSW for increasing the length of plate.</b>	<b>85</b>
4-51	<b>Energy dissipation of CSPSW for increasing the height of plate.</b>	<b>86</b>
4-52	<b>Energy dissipation of CSPSW for increasing the length of plate.</b>	<b>86</b>
4-53	<b>Case of opening in corrugated plate.</b>	<b>89</b>
4-54	<b>Ultimate strength of CSPSW with circular opening.</b>	<b>90</b>
4-55	<b>Ultimate strength of CSPSW with square opening.</b>	<b>90</b>
4-56	<b>Stiffness of CSPSW with circular opening.</b>	<b>91</b>
4-57	<b>Stiffness of CSPSW with circular opening.</b>	<b>92</b>
4-58	<b>Ductility ratio of CSPSW with circular opening.</b>	<b>93</b>
4-59	<b>Ductility ratio of CSPSW with square opening.</b>	<b>93</b>
4-60	<b>Energy dissipation of CSPSW with circular opening.</b>	<b>94</b>
4-61	<b>Energy dissipation of CSPSW with circular opening.</b>	<b>94</b>



## A List of Tables

Table No.	Title of table	Page No.
3-1	<b>Mechanical properties of Emami specimens</b>	<b>32</b>
3-2	<b>Mechanical properties of Hosseinzadeh specimens</b>	<b>33</b>
3-3	<b>True value for Emami specimens</b>	<b>34</b>
3-4	<b>True value for Hosseinzadeh specimens</b>	<b>34</b>
3-5	<b>Strength value of the numerical and experimental test.</b>	<b>39</b>
4-1	<b>The parametric study of the CSPSW</b>	<b>44</b>
4-2	<b>Correlation of the vertical corrugation plate with 1.25mm</b>	<b>57</b>
4-3	<b>Correlation of the horizontal corrugation with 1.25mm</b>	<b>57</b>
4-4	<b>Correlation of the vertical corrugation with 2mm</b>	<b>58</b>
4-5	<b>Correlation of the horizontal corrugation with 2 mm</b>	<b>58</b>
4-6	<b>Correlation of the vertical corrugation with 3mm</b>	<b>59</b>
4-7	<b>Correlation of the horizontal angle with 3mm</b>	<b>59</b>
4-8	<b>Correlation of change of horizontal side for vertical corrugation with 1.25mm</b>	<b>68</b>
4-9	<b>Correlation of change of horizontal side for horizontal corrugation with 1.25mm</b>	<b>68</b>
4-10	<b>Correlation of change of horizontal side for vertical corrugation with 2mm</b>	<b>69</b>
4-11	<b>Correlation of change of horizontal side for horizontal corrugation with 2mm</b>	<b>69</b>
4-12	<b>Correlation of change of horizontal side for vertical corrugation with 3mm</b>	<b>70</b>
4-13	<b>Correlation of change of horizontal side for horizontal corrugation with 3mm</b>	<b>70</b>
4-14	<b>Correlation of inclined side for vertical corrugation with 1.25mm</b>	<b>78</b>
4-15	<b>Correlation of inclined side for horizontal corrugation with 1.25mm</b>	<b>79</b>

4-16	<b>Correlation of inclined side for vertical corrugation with 2mm</b>	<b>79</b>
4-17	<b>Correlation of inclined side for horizontal corrugation with 2mm</b>	<b>79</b>
4-18	<b>Correlation of inclined side for vertical corrugation with 3mm</b>	<b>80</b>
4-19	<b>Correlation of inclined side for horizontal corrugation with 3mm</b>	<b>80</b>
4-20	<b>Correlation of increasing the height of plate for vertical corrugation</b>	<b>87</b>
4-21	<b>Correlation of increasing the height of plate for horizontal corrugation</b>	<b>87</b>
4-22	<b>Correlation of increasing the length of plate for vertical corrugation</b>	<b>88</b>
4-23	<b>Correlation of increasing the length of plate for horizontal corrugation</b>	<b>88</b>
4-24	<b>Correlation of circular opening plate for vertical corrugation</b>	<b>95</b>
4-25	<b>Correlation of circular opening plate for horizontal corrugation</b>	<b>95</b>
4-26	<b>Correlation of square opening plate for vertical corrugation</b>	<b>96</b>
4-27	<b>Correlation of square opening plate for horizontal corrugation</b>	<b>96</b>

## A List of Symbols

$\tau_{cr,L}^E$	The local buckling strength
$\tau_{cr,G}^E$	The global buckling strength
$\tau_{cr,I}^E$	The interactive buckling strength
$\tau_y$	The shear yield strength
E	Young's modulus of elasticity
$\nu$	Poisson's ratio
a	The maximum width of a horizontal or inclined side
t	The plate thickness
K	The buckling coefficient defined according to the boundary conditions and aspect ratio of the horizontal side.
$D_x, D_y$	The longitudinal and the transverse bending stiffness per unit length of the corrugated plate
$I_x, I_y$	Moment of inertia
$\beta$	The global buckling coefficient that changes from 1.0 to 1.9 according to the boundary conditions between the plate and frame.
$C_d$	The displacement modification factor
$\Omega_0$	system over strength factor
$\sigma_{true}$	True stress value
$\sigma_{engineering}$	Engineering stress value
$\epsilon_{true}$	True total strain
$\epsilon_{plastic}$	True plastic strain
$P_{peak}$	The maximum load resisted by the specimen in the envelope curve.
$\Delta_e$	Displacement of the top edge of the specimen at $0.4 P_{peak}$
$\mu$	The ductility ratio

$\delta_{\max}$	Maximum displacement of the edge of specimen
$\delta_y$	The displacement at the yield point.
$r_{xy}$	The personal correlation.

## A List of Abbreviations

Symbol	Definition
AED	approximate elastic displacement
CSPSW	Corrugated steel plate shear wall
CSW	composite shear wall
DSPSW	Double steel plate shear wall
FEM	Finite Element Method
Fig.	Figure
$h_P$	Height of corrugated plate
$L_P$	length of corrugated plate
PFI	Plate Frame Interaction
RCSW	reinforced concrete shear wall
SPSW	Steel Plate Shear Wall

# Chapter one

## Introduction

### 1.1 General

In many countries, the buildings and facilities are designed to resist seismic loads. More than 16,000 buildings are protected in the world through seismic isolation, energy dissipation and other seismic systems (M.Mazzolani and Herrera, 2012) which differ according to the importance of the building, service and economic factors, The absence of this system leads to losing the safety of buildings and may cause a loss in the integrate of buildings and even the collapse the building subjected to an earthquake.

Shear walls are one of the systems that act as part of the lateral loads resisting systems. The systems of the shear walls are mainly divided into three major types: the Reinforced Concrete Shear Wall (RCSW), the Steel Plate Shear Wall (SPSW), and the Composite Shear Wall (CSW) which consists of concrete with a steel plate(Ashour, 2016), shown in **Fig. (1-1)**.



**Fig. (1-1) : Location and shape of the steel plate and RC shear walls.**

Steel Plate Shear Wall (SPSW) can be divided into stiffened and unstiffened. The use of SPSW has increased in recent years because they have a number of advantages over other systems (Astaneh-Asl and Council, 2001) such as:

1. SPSW has the high stiffness, ductility, as well as the high ability to dissipate energy making it one of the best types in the systems of resistance lateral loads.
2. SPSW is lighter than the other types of the shear wall which lead to a dead load reduction, a decrease in the size of the foundations and the cost as well.
3. The use of SPSW leads to speeding up the construction process and reducing the time and effort as compared with other types.
4. The use of SPSW in high rise buildings provides a better space than that the used RC shear wall does with the same efficiency. The RC shear wall used in high rise buildings increases the thickness of the walls, especially on the ground floors.
5. The process of repairing SPSW is easier and less costly than other types of repair when used in seismic retrofit of existing building.

Because of the early elastic buckling of a plate often avoids the use of SPSW in high buildings. This happens due to the gravity loads of the upper floors that transfer from the boundary frames and the floors during the constructions or under the low level of the lateral loads in service. Therefore, there is a need to find a method to strengthen the plate without welding the stiffeners or casting concrete. The best alternative is the corrugated steel plate shear walls(Zhao et al., 2017).

The Corrugated Steel Plate Shear Wall (CSPSW) is another kind of the lateral load opposing system within the family of SPSW. CSPSW consists mainly of the steel frame (two beams and two columns), and the steel plate which is connected to steel frame by welding bolts or both(Zhao et al., 2017). In general, the CSPSW as the SPSW which usually installs one or more bays along the height of the buildings with regular or irregular distribution according to design purposes as shown in **Fig. (1-2)**.

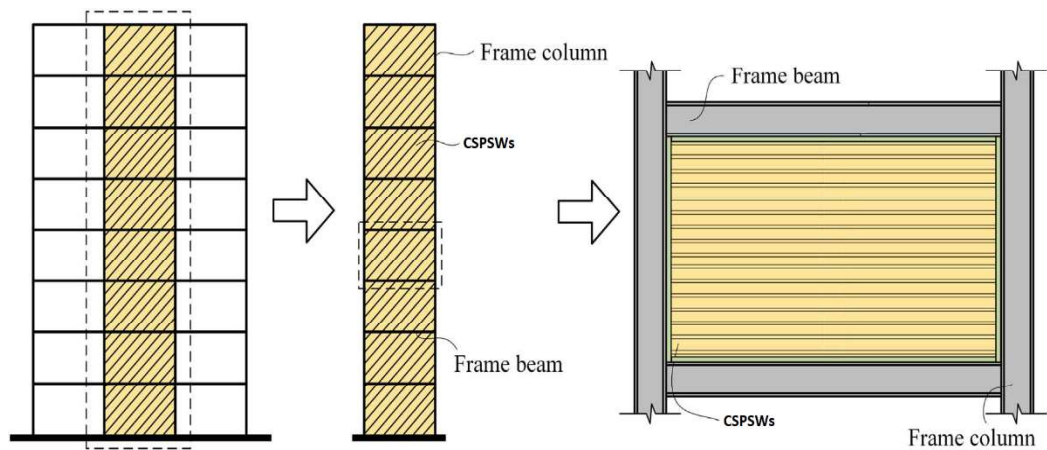

**Fig. (1-2) : CSPSW in the building and the geometric shape (Zhao et al., 2017).**

The corrugated plate is categorized by three aspects: the angle of corrugation, the horizontal side, and the inclined side which form the ribs. The ribs are one of the advantages of the geometric shape of the corrugated plate. They act as stiffeners to the plate. Due to the geometric shape of a plate, the ductility, initial stiffness, energy dissipation, and the ability to oppose the gravity loads improve in comparison with the SPSW. In addition, the cost reduces because there is no need to stiffen the plate (Zhao et al., 2017). The corrugated plate is divided according to the direction of corrugation to the vertical corrugated plate and horizontal corrugated one as shown in **Fig. (1-3)**.

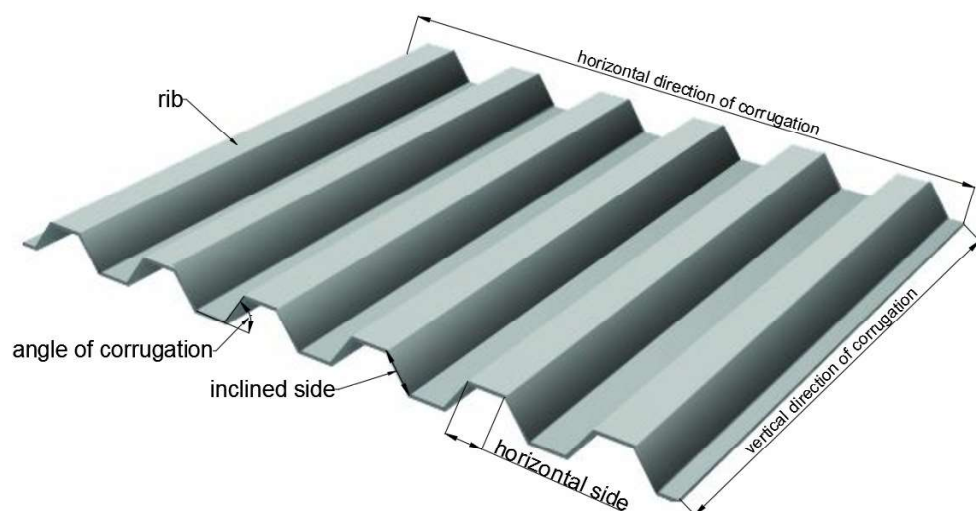

**Fig. (1-3): Details of the geometric shape of CSPSW.**



## 1.2 Behavior of corrugated steel plate shear wall

The effect of the cyclic loading on the behavior of the corrugated plate and the frame that is usually influenced by the thickness of plate, rigidity and stiffness of the frame. The aspect ratio of the plate, connection of the columns to adjacent storey, and divided the loads on the height of the shear wall also effected on the on the behavior of the shear walls (Moghimi and Driver, 2014).

After subject the CSPSW to the later load two stresses appears as compressive and tensile principal stress in the plate that leads to the appearance the buckling in the plate. The left column is then affected by tension force and the right column by the compression forces as shown in **Fig. (1-4)**.

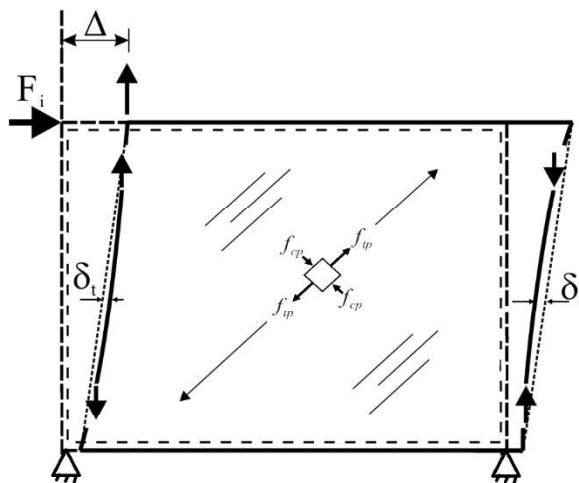

**Fig. (1-4) :** The effect of the later load on the CSPSW (Moghimi and Driver, 2014) .

### 1.2.1 Buckling type

#### 1.2.1.1 The local buckling

The local buckling occurs in the corrugated plate when the percentage of the horizontal side length to the thickness is excess of 60 time. It leads to the appearance of the local buckling, as shown in **Fig. (1-5)**. this can be calculated by using equation (1.1). (Yi et al., 2008):

$$\tau_{cr,L}^E = k \times \frac{\pi^2 E}{12(1-\nu^2)} \left(\frac{t}{a}\right)^2 \quad (1.1).$$

Where  $\tau_{cr,L}^E$  = the local buckling strength (kN/mm<sup>2</sup>).

$\nu$  = Poisson's ratio

E = Young's modulus of elasticity (kN/mm<sup>2</sup>).

t = the plate thickness (mm).

a = the maximum width of a horizontal or inclined side (mm).

k = the buckling coefficient defined according to the boundary conditions and aspect ratio of the horizontal side.

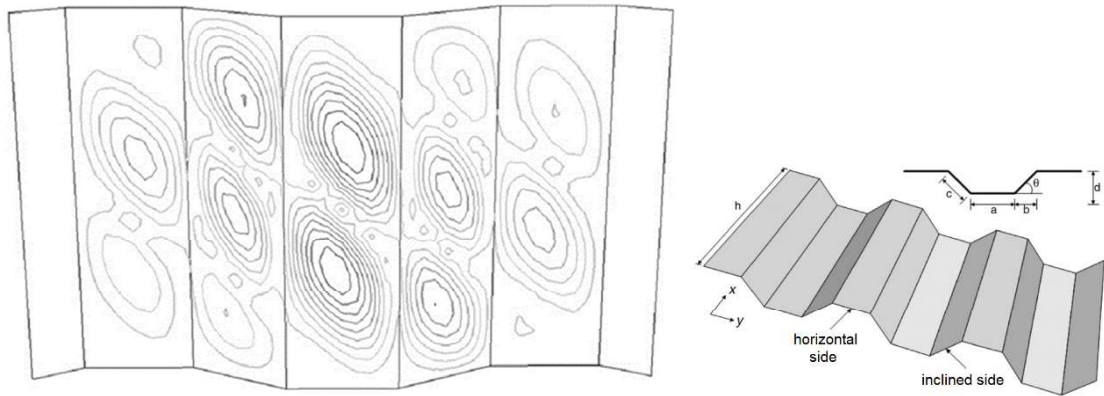

**Fig. (1-5) : Local buckling in the corrugated plate(Yi et al., 2008).**

### 1.2.1.2 The global buckling

The global buckling occurs when the number of ribs dense increasing the corrugation which leads to the appearance the global buckling as shown in **Fig. (1-6)**. Buckling strength can be calculated using equation(1.2) (Yi et al., 2008) :

$$\tau_{cr,G}^E = 36\beta \times \frac{D_y^{\frac{1}{4}} D_x^{\frac{3}{4}}}{t h^2} \quad (1.2).$$

Where  $\tau_{cr,G}^E$  = the global buckling strength,

$D_x = E I_x$  ,  $D_y = E I_y$  are the longitudinal and the transverse bending stiffness per unit length of the corrugated plate

$\beta$  = the global buckling coefficient that changes from 1.0 to 1.9 according to the boundary conditions between the plate and frame.

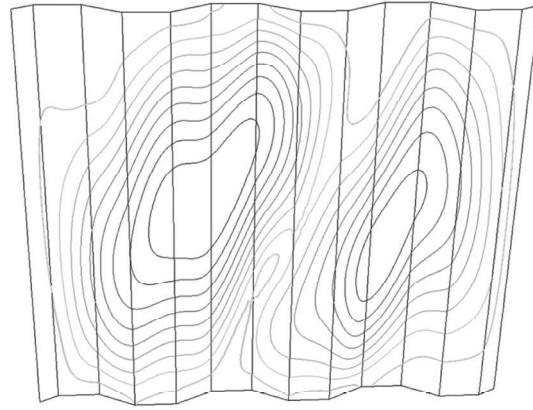

**Fig. (1-6) : Global buckling in the corrugated plate(Yi et al., 2008).**

### 1.2.1.3 The interactive buckling

The interactive buckling located between the global and local bulking depends mainly on the geometric shape of a corrugated plate as shown in **Fig. (1-7)**. Buckling strength can be calculated by using the following equation (1.3)(Yi et al., 2008):

$$\frac{1}{(\tau_{cr,I}^E)^n} = \frac{1}{(\tau_{cr,L}^E)^n} + \frac{1}{(\tau_{cr,G}^E)^n} + \frac{1}{(\tau_y)^n} \quad (1.3).$$

Where  $\tau_{cr,I}^E$  = the interactive buckling strength (kN/mm<sup>2</sup>).

$\tau_{cr,L}^E$  = the local buckling strength (kN/mm<sup>2</sup>).

$\tau_{cr,G}^E$  = the global buckling strength (kN/mm<sup>2</sup>).

$\tau_y$  = the shear yield strength (kN/mm<sup>2</sup>).

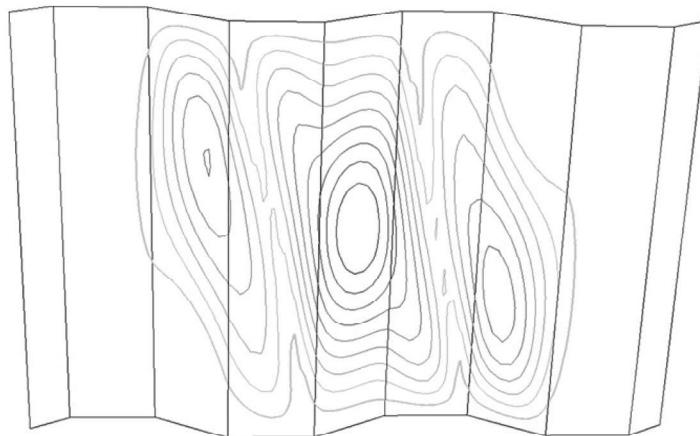

**Fig. (1-7) : Interactive buckling in the corrugated plate (Yi et al., 2008).**

### **1.3 Aim and objectives of the study**

This study aims at studying the structural behavior of the CSPSW and investigating the influential parameters that can affect the CSPSW performance through:

- 1- Forming and validating a finite element model (FEM) for CSPSW under the effect of cyclic loads with as much as possible efficiency.
- 2- Determining factors affecting CSPSW performance.
- 3- Studying the effect of these factors and the effect of correlating these factors on corrugated steel plate performance.
- 4- Determining the value of the ultimate load, ductility, stiffness and energy dissipation through the analysis of the models.
- 5- Determining the best cases for a corrugated plate that gives a better performance through the results of the study.

### **1.4 Scope of study**

This study considers the effect of the parameters below on the performance of the CSPSW:

- 1- Angle of corrugation
- 2- Horizontal side of the corrugated plate.
- 3- Inclined side of corrugated plate.
- 4- Thickness of the corrugated plate.
- 5- Effect of opening.
- 6- Direction of corrugation.
- 7- Aspect ratio of the corrugated plate.

### **1.5 Methodology**

In order to complete this study two experimental programs (Emami 2013, Hosseinzadeh 2017) are used as a guideline for adopted forming and validation of the FE model of CSPSW. Where ABAQUS/2017 used to building the FE models. After that the numerical results from analysis the

models are compared with the experimental data in order to check solution and achieve the accuracy in analysis.

The second part of this thesis includes a parametric study in order to investigate the effects of parametric study on the behavior of CSPSW and discuss the results to determine the better performance of CSPSW. Where the performance is assessed by value of the initial stiffness, ductility ratio, strength and energy dissipation.

### **1.6 Outline of Thesis**

The thesis consists of five chapters which are outlined as follows:

**Chapter 1:** present a general introduction about the shear wall, CSPSW, and the behavior of CSPSW with the scope, objectives, and methodology of the study.

**Chapter 2:** provides a review of previous studies concerning the experimental and analytical studies carried out on CSPSW.

**Chapter 3:** describes the FE model that is developed to predict the behavior of CSPSW and presents the validation of the finite element model of CSPSW.

**Chapter 4:** describes in details the case study of the CSPSW under cyclic loading.

**Chapter 5:** present the main conclusions of the study along with some suitable recommendations for future work on CSPSW system.