

**Ministry of Higher Education
And Scientific Research
University of Diyala
College of Engineering**



ESTIMATION OF RESIDUAL STRESSES AND CORROSION BEHAVIOR IN MACHINING OF NICKEL-BASE SUPERALLOY

**A Thesis Submitted to Council of College of Engineering,
University of Diyala in Partial Fulfillment of the Requirements for
Master Degree in Mechanical Engineering Science .**

by

Khalaf Nasiralla Khalaf

Supervised by

Prof. Adel K. Mahmoud(Ph.D.)

Asst. Prof. Suha K. Shihab(Ph.D.)

2019 A.D

IRAQ

1440 A.H

بِسْمِ اللَّهِ الرَّحْمَنِ الرَّحِيمِ

﴿ نَرْفَعُ دَرَجَاتٍ مَّن نَّشَاءُ وَفَوْقَ كُلِّ ذِي

عِلْمٍ عَلِيمٌ ﴾

صدق الله العظيم

((يوسف، 76))

In the Name of ALLAH, the Most Beneficent ,the Most Merciful
((We raise in degree who We will, but over every Lord there
is One more Knowledge))

God Almighty has spoken the truth

Suret Yosif,vers,76

COMMTTEE CERTIFICATION

We certify that we have read the thesis entitled “**Estimation of Residual Stresses and Corrosion Behavior in Machining of Nickel-Base Superalloy**” and we have examined the student (**Khalaf Nasiralla Khalaf**) in its content and what is related with it ,and in our opinion it is adequate as a thesis for **Degree of Master of Science in Mechanical Engineering**.

Signature.....

Prof. Dr. Adel K. Mahmoud
(Supervisor)

Signature.....

Asst. Prof. Dr. Suha K. Shihab
(Supervisor)

Signature.....

Prof. Dr. Muhsin J.Jweeg
(Chairman)

Signature.....

Asst.Prof. Dr.Jummaa Salman Chiad
(Member)

Signature.....

Asst.Prof. Dr. Dhia Ahmed Salal
(Member)

Signature.....

Asst.Prof. Dr. Dhia Ahmed Salal
(Head of Department)

The thesis was ratified at the Council of College of Engineering/University of Diyala.

Signature.....

Prof.Dr. Abdul Mun'em Abbas Karim

Dean of College of Engineering / University of Diyala.

Date: / /2019

DEDICATION

This study is dedicated to:

**The teacher of human knowledge of
our Prophet Muhammad (peace be upon him)**

My Soul father and my mother

**My family and children, with love ,respect and
gratitude.**

ACKNOWLEDGEMENT

Firstly, I want to thank (ALLAH)for giving me the impatient and incurring to finish this study, I would like to thank the people and sponsors who made this study possible to finish it.

Special thank goes to my Supervisor Professor Dr. **Adel K. Mahmoud** and Asst. Prof. Dr. **Suha K. Shihab** for their support and guidance throughout my time at College of Engineering.

Deep thank due to the staff of Mechanical Engineering and all person who help me in College of Engineering.

Last but not least, I want thank all my brothers and friends for their continuous support and encouragement throughout my research. I am truly grateful for all that they have done.

ABSTRACT

Estimation of Residual Stresses and Corrosion Behavior in Machining of
Nickel-Base Superalloy

by

Khalaf Nasiralla Khalaf

Supervised by

Prof. Dr. Adel K. Mahmoud

Supervised by

Asst. Prof. Dr. Suha K. Shihab

Inconel 718, a representative nickel base superalloy, is widely used in the gas turbines, aircraft, heat treating equipment's, nuclear power plants, petrochemical industries and Chemical due to its high temperature endurance properties and excellent corrosion resistance. However, the turning of Inconel 718 produces more generations heat in the cutting zone than that of greatest other materials and alloys which makes this material prone to surface defects. The aim of this study is to evaluate the effect of different turning parameters i.e. cutting speed (v), feed rate (f) and depth of cut (d) on the responses i.e. surface integrity including surface roughness (R_a), microhardness (HV), residual stresses and corrosion behavior for nickel base superalloy (Inconel 718) during dry turning using coated carbide tools. Experiments were designed using design of experiment (DOE) Taguchi method and experimental runs are conducted for various combinations of turning parameters to find the optimum machining parameters that achieve better surface quality with minimum corrosion rate. Analysis of variance (ANOVA), correlation and regression techniques are employed to determine the significance of turning parameters. In addition, a numerical model using 3D finite element method (FEM) is performed by ABAQUS software to examine the machined surface temperature

distribution and residual stresses induced by turning and the results of the models are validated by comparison them with experimental results. The comparison showed a good agreement more than (90%) between the 3D FEM modeling of the oblique machining and experimental results. Moreover, the results showed that the feed rate has the most significant(66%) effect on the surface roughness and the best surface quality is achieved using the highest cutting speed and lowest feed rate and depth of cut. The cutting speed has the most significant(56%),(63%)and (50%) respectively effect on the residual stresses(Rs), microhardness(Hv) and machined surface temperature(°C). Also, it was found that the temperature generation during high-speed turning of is found to play a major role in residual stress magnitude. The surface roughness and compressive residual stresses are very important factors which play major effect on the corrosion behavior of Inconel 718. In this way, the feed rate is showed the most significant(72%) factors for minimizing the corrosion rate in Inconel 718 alloy .The results obtained by this research will be fruitful for various industries and researchers who are working in this field.

Keywords: - Machining; Inconel 718; Residual stresses; Corrosion Behaviour; 3D- FEM; Taguchi design.

TABLE OF CONTENTS

Titles		Page No.
Dedication		
Acknowledgement		
Abstract		I
Table of Contents		III
List of Tables		VI
List of Figures		VIII
List of Abbreviations		XII
List of Symbols		XIII
Chapter One : General Introduction		
1.1	General	2
1.2	Superalloys	2
1.2.1	Classification of Superalloys	5
1.2.2	Applications of Inconel718	6
1.3	Machining of Inconel 718	7
1.4	Surface Integrity	10
1.4.1	Residual Stresses	10
1.4.2	Surface Roughness	12
1.4.3	Hardness	13
1.5	Corrosion	13
1.5.1	Corrosion Types	14
1.5.2	Corrosion of Ni-based Superalloys	15
1.6	Problem Statement	16
1.7	The Aim of the Study	16
1.8	Study Organization	17
Chapter Two: Literature Review		
2.1	Introduction	20
2.2	Residual Stresses in Turning Process	20
2.3	Surface Roughness	27

2.4	Microhardness	32
2.5	Temperature Prediction	34
2.6	Corrosion	37
2.7	Research Gaps	39
Chapter Three : Methodology and Experimental Work		
3.1	Introduction	41
3.2	Plan of the Study	42
3.3	Cutting Tool	42
3.3.1	Tool Geometry	43
3.3.2	Tool Insert	44
3.3.3	Tool Holders	45
3.4	Workpiece Material	46
3.5	Cutting Parameters	47
3.6	CNC Lath Machine	49
3.7	Surface Roughness	50
3.7.1	Average Roughness Parameters	50
3.7.2	Roughness Measurement	51
3.8	Hardness	52
3.8.1	Sample Preparation	52
3.8.2	Microhardness Measurement	53
3.9	Residual Stresses	54
3.9.1	Residual Stresses Measurement	56
3.10	Corrosion of Inconel 718	58
3.10.1	Corrosion Rate Calculation	61
3.10.2	Electrochemical Preparation of Sample	62
3.10.3	Corrosion Test	64
3.10.4	Open Circuit Potential Test (OCP)	64
3.11	Design of Experimental (DOE)	64
3.11.1	Taguchi Design	65
3.11.2	Taguchi's Orthogonal Arrays	67
3.11.3	ANOVA Analysis	68
3.12	3D Finite element Modelling of Turning Process	69

3.12.1	Modelling of Cutting Tool	71
3.12.2	Modelling of Workpiece	72
3.12.3	Modelling of Temperature	75
3.12.4	Boundary Conditions	76
Chapter Four : Results and Discussion		
4.1	Introduction	79
4.2	Surface Roughness Analysis	79
4.3	Microhardness Analysis.	85
4.4	Experimental Analysis of Residual Stresses	90
4.5	Numerical Analysis of Residual Stresses	96
4.5.1	Analysis of Machined Surface Temperature	105
4.6	Corrosion Behavior	112
Chapter Five : Conclusions & Suggestions for Future work		
5.1	Conclusions	121
5.2	Suggestion for Future work	122
	References	123
	Appendices	
	Abstract in Arabic	

LIST OF TABLE

Table Number	Table Title	Page No.
Table 1.1	Contents of main elements in superalloys	3
Table 1.2	Properties of nickel alloys at room temperature	4
Table 1.3	Common three type of super alloy	5
Table3.1	Insert Specific details	45
Table 3.2	Toolholder dimensions	46
Table 3.3	Chemical composition of Inconel 718 (%)	47
Table 3.4	Cutting parameters and their level	49
Table 3.5	The recommended performance statistics	67
Table 3.6	Three Level Design	68
Table 3.7	Geometric variables of the cutting tool	72
Table 3.8	Thermal and mechanical properties of cutting tool used in FEM	71
Table 3.9	Physical, thermal Properties of Inconel 718	74
Table 3.10	Johnson-Cook material model constants for Inconel 718	73
Table 4.1	Experimental surface roughness and S/N ratio	80
Table 4.2	Response for roughness	83
Table 4.3	ANOVA result for roughness	83
Table 4.4	Result of conformation test for surface roughness	84
Table 4.5	Experimental Microhardness and S/N ratio	85
Table 4.6	Response for Microhardness	88
Table 4.7	ANOVA results for microhardness	88
Table 4.8	Result of conformation test for microhardness	90
Table 4.9	Experimental residual stress values and S/N ratio	91
Table 4.10	Response for residual stresses	95
Table 4.11	ANOVA results for residual stresses	95
Table 4.12	Simulated value of residual stresses	97
Table 4.13	Simulate temperature and corresponding S/N ratio	107
Table 4.14	Response table for temperature	110
Table 4.15	ANOVA result for temperature	110

Table 4.16	Experimental results and corresponding S/N ratio	114
Table 4.17	Response for corrosion rate	118
Table 4.18	ANOVA results for corrosion rate	118
Table 4.19	Result of conformation test for corrosion rate	119

LIST OF FIGURES

Figure Number	Figure Title	Page No.
Figure 1.1	Some application of nickel base super alloy	7
Figure 1.2	Types of Cutting	8
Figure 1.3	Machining methods for conversion of final engineering products	10
Figure 1.4	Classification of residual stresses techniques	12
Figure 1.5	Based on their simplicity of the major corrosion forms are grouped	15
Figure 3.1	Flow chart for plan of study	42
Figure 3.2	Cutting tool geometry	43
Figure 3.3	Cutting tool	44
Figure 3.4	Insert Geometry	44
Figure 3.5	Toolholder with Insert	45
Figure 3.6	workpiece ,toolholder and cutting too insert arrangement	46
Figure 3.7	Machined workpiece samples	47
Figure 3.8	Adjustable parameters in turning operation	48
Figure 3.9	Experimental setup on CNC machine	49
Figure 3.10	Schematic of a surface profile $z(x)$	50
Figure 3.11	Roughness device	51
Figure 3.12	The experimental set up for cutting sample on wire-EDM	53
Figure 3.13	Digital Micro Vickers Hardness Tester	54
Figure 3.14	Superposing of residual stress and service stress	55
Figure 3.15	Effect of residual stress on the performance of material	55
Figure 3.16	ORIONRKS 6000 XRD Device	58
Figure 3.17	Anodic and Cathodic reactions on the surface of the alloy	59
Figure 3.18	(a) representative diagram from the electrochemical cell, (b) The electrochemical cell	60

Figure 3.19	anodic and cathodic reaction on Tafel curve	61
Figure 3.20	Prepare sample for corrosion test	63
Figure 3.21	Experimental Setup of Corrosion Test	64
Figure 3.22	Classification of modeling and optimization techniques	65
Figure 3.23	The Turning Simulation Methodology	70
Figure 3.24	3D finite element model for turning	71
Figure 3.25	(a)Real cutting tool (b) simulated of the tool insert with Mesh	73
Figure 3.26	The meshing of workpiece and cutting tool	75
Figure 3.27	Boundary condition of model	76
Figure 3.28	Flow chart gradual process to model workpiece and cutting tool.	77
Figure 4.1	Main effect plot for Roughness	81
Figure 4.2	Normal probability plot for roughness	81
Figure 4.3	Contour graph shows the effect of v, f, d on Ra	82
Figure 4.4	Measured and predict values of surface roughness	84
Figure 4.5	Main effect for microhardness	86
Figure 4.6	Normal probability plot for microhardness	87
Figure 4.7	Contour graph shows the effect of v, f, d on microhardness	88
Figure 4.8	Measured and predicted values of microhardness	90
Figure 4.9	Main effects for residual stresses	92
Figure 4.10	Normal probability plot for residual stresses	93
Figure 4.11	Contour graph shows the effect of v, f, d on residual stresses	94
Figure 4.12	Measured and predicted values of Residual stresses	96
Figure 4.13	Simulated type of Residual stresses distribution using FEM with ALE	98
Figure 4.14	Measured and predicted values of residual stresses	99

Figure 4.15	Simulated circumferential Residual stresses profile for run No.(1)	100
Figure 4.16	Simulate circumferential Residual stresses profiles run No.2	101
Figure 4.17	Simulate circumferential Residual stresses profiles run No.3	101
Figure 4.18	Simulate circumferential Residual stresses profiles run No.4	102
Figure 4.19	Simulate circumferential Residual stresses profiles run No.5	102
Figure 4.20	Simulate circumferential Residual stresses profiles run No.6	103
Figure 4.21	Simulate circumferential Residual stresses profiles run No.7	103
Figure 4.22	Simulate circumferential Residual stresses profiles run No.8	104
Figure 4.23	Simulate circumferential Residual stresses profiles run No.9	104
Figure 4.24	3D simulation results using ALE for machined surface temperature	106
Figure 4.25	Main effect plot for temperature	108
Figure 4.26	Normal probability plot for temperature	108
Figure 4.27	Contour graph shows the effect of v, f, d on temperature	109
Figure 4.28	Temperature distribution in the machined surface for run No.1	111
Figure 4.29	Measured and predict values of temperature	112
Figure 4.30	Tafel extrapolation run No.1	112
Figure 4.31	Polarization curve of Inconel 718 alloy for run No.1	113
Figure 4.32	Main effect of S/N ratio for corrosion rate	115
Figure 4.33	optical surface examination with(100x) for the machined surfaces	116

Figure 4.34	Normal probability plot for corrosion rate	116
Figure 4.35	Contour graph shows the effect of v, f, d on corrosion rate	117
Figure 4.36	Measured and predicted values corrosion rate	119

LIST OF ABBREVIATIONS

Symbol	Definition
A	Initial yield strength parameter for Johnson–Cook material
AISI	American Iron and Steel Institute
ANSI	American National Standards Institute
ALE	Adaptive Langrangian Eulerian
B	Hardening modulus parameter for Johnson–Cook material model
C	Strain rate parameter for Johnson–Cook material model
CLA	Center Line Average
CVD	Chemical Vapour Deposition Coated Insert
CNC	Computer numerical control
CR	Corrosion Rate
DOE	Design of experimental
<i>d</i>	Depth of Cut
<i>E</i>	Elastic Modulus (Pa)
EDM	Electrical Discharge Machine
E_{corr}	Corrosion Potential
Fcc	Face-Centered Cubic
FEM	Finite Elements Method
<i>f</i>	Feed Rate
I_{corr}	Corrosion Current Density
JC	Johnson–Cook
MQL	Minimum Quantity Lubrication
OCP	Open Circuit Potential
PVD	physical Vapour Deposition Coated Insert
RS	Residual Stresses
S/N	Signal to-Noise ratio
T	Temperature
T_m	Material Melting Temperature
<i>v</i>	Cutting Speed
A, B, C, m, n	Johnson-Cook Flow Stress Parameters
WC	Tungsten Carbide Cutting Tool
XRD	X-ray diffraction

LIST OF SYMBOLS

Abbreviations	Meaning
$\bar{\epsilon}$	Equivalent plastic strain
α	Tool rake angle
σ	Stress(Pa)
σ_{11}	Stress x- axes(Pa)
σ_{22}	Stress y- axes(Pa)
σ_{33}	Stress z- axes(Pa)
θ	Theta(°)
α	Alpha(°)
τ	Shear stress (Pa)
ϵ	Shear strain
τ_y	Initial shear yield strength (Pa)
ρ	Density (kg/m^3)
ν	Poisson's ratio
2θ	Bragg angle(°)

Chapter One

General

Introduction

1.1 General

This chapter is focused on overall information about superalloy and specially on Nickel-base superalloys, their properties, their chemical composition and classification of superalloys. In addition, importance of Inconel 718 and its industrial application, machining of Inconel 718 and difficulty of machining superalloy has been clarified. Then, residual stresses definition, types of residual stresses, and their advantage and disadvantage, the common techniques used for measuring of residual stresses were explained. Finally, corrosion type and corrosion behavior of superalloys were indicated in this chapter.

1.2 Superalloys

Recently, developments in the automotive and aerospace manufacturing led to high need of high performance alloys (superalloys) because of their beneficial mechanical and physical attributes like high-yield strength, exceptional fatigue endurance, low-thermal conductivity, and decent corrosion persistence in difficult circumstances, mainly in developing pieces for gas turbines and jet engines [1]. Nickel (Ni) is widely-utilized in various industries even when it is confirmed, it has some toxic features. Superalloys could be nickel-based alloys, iron-nickel-based alloys or cobalt-based alloys which are utilized when the temperature is over 540 Celsius [2,4]. Table 1.1 shows the Contents of main elements in superalloys. The 1st created generation of superalloys has been intended for temperature up to 700 Celsius, whereas the 4th created generation of superalloys have been made and utilized as a single crystal material, also they have been alloyed through unique elements, like the ruthenium (Ru) and it could be utilized at temperature up to 1100 Celsius [2,4].

Table 1.1 Contents of main elements in superalloys [2]

Fe- Based										
Element	Ni	Fe	Ti	Al	Mo	Co	Cr	Nb	W	C
Wt.%	9-44	29-67	0-3	0.3-1	0-3	0-20	0-25	0-5	0-2.5	<0.35
Co- Based										
Element	Co	Ni	Ti	Al	Mo	Fe	Cr	Nb	W	C
Wt.%	do 62	0-35	0-3	0-0.2	0-10	0-21	19-30	0-4	0-15	0-1
Ni- Based										
Element	Ni	Ti	Al	Mo	Co	Cr	Nb	W	C	
Wt.%	37-79.5	0-5	0-6	0-28	0-20	5-22	0-5.1	0-15	<0.30	

In 1930's, developing Ni-based superalloys for aerospace uses has been initiated. New high-performance alloys has been developed due to the necessity for additional creep-resistant materials than the existing austenitic stainless steel. The exceptional strength retention which is up to 0.7 (T_m) melting point and the high-phase stability of face centered cubic (FCC) nickel matrix are both considered the main features of Ni as an alloy-base. Various applications which are put through high temperatures uses Ni-based superalloys because of the above-mentioned features [1]. Examples of the commercially obtainable Ni-based Superalloys are Pyromet, Udimet, Rene, Nimonic and Inconel. Alloy 718 is a face-centered cubic (FCC) nickel-based superalloy and initially referred to as Inconel 718 due to the trademark. The most commonly utilized Ni-based superalloy is the Inconel 718.[5]. The mechanical properties regarding common Ni alloys are shown in the Table1.2.

Table 1.2 Properties of Nickel alloys at room temperature[2]

Alloy	Yield strength (MPa)	Ultimate tensile stress (MPa)	Elongation (%)	Young modulus (GPa)	Hardness
Nickel 200	148	462	47	204	109HB
Dura nickel 301	862	1170	25	207	30-40HRC
Ni-Cu					
Alloy-400	240	550	40	180	110-150HB
Alloy R-405	240	550	40	180	110-140HB
Alloy K-500	790	1100	20	180	300HB
Ni-Cr-Fe-Mo					
Alloy 600	310	655	40	207	75HRB
Alloy-718	1036	1240	12	211	36HRC
Alloy 800	295	600	44	193	138HB
Alloy 925	815	1210	24	-	36.5HRC
Alloy B – cast N-12MV	275	525	6		
Ni-Al-Cr superalloys					
Inconel 718	1100	1375	25		
Haynes 230	390	860	47.7	211	
Nimonic 80A	780	1250	30		
Inconel 600	310	655	45		

New high-performance systems including the gas turbines, high-efficiency internal combustion engines and the jet engines have requirements that exceed the mechanical or thermal capabilities of most conventional materials. Nickel-based superalloys are commonly used in these hostile environments, due to their high resistance to oxidation, corrosion and good thermal fatigue-resistance properties at high temperature. However, their unique physical properties result in low machinability, Subsurface damage, which always detrimental to product performance, is becoming a more significant machining characteristic as higher performance is demanded from these high end materials and products [6].

When producing parts of aircrafts and gas turbines, the needed features in addition to the surface's characteristics (microhardness and roughness) but also the features below the surface like residual stresses. Subsurface damage is typically generated during the machining of these materials [7]. Therefore, it is very important to study the induced residual stresses during machining of nickel-based superalloys.

1.2.1 Classification of Superalloys

Superalloys might be classified to 3 types according their main element, the types are presented in Table 1.3:

Table 1.3 Common three types of superalloys. [1]

Iron-based superalloys	Cobalt-based superalloys	Nickel-based superalloys
Incoloy series Discaloy Haynes 556 N-155 Pyromet CTX-1 RA330 A-256	MAR-M 302 MAR-M 509 MP-35N MP-159 Stellite 6B WI-52 X-40	Hastelloy series Inconel series NA-224 Nimonic series Udimet series Rene' series Waspaloy Astroloy

1. Iron-based superalloys (Fe-Ni):

Irons based superalloys are considered as an advance that made from the austenitic stainless steels, also they depend on the process of combining (in most of the situations) precipitate forming elements and solid solution hardening with closed packed (FCC) matrix. Iron and nickel are the base which austenitic matrix depends on, the (FCC) stage needs at least 25 % of Ni to be stabilized. Nickel or cobalt based superalloys cost more than iron based superalloys [2,3].

2. Cobalt-based superalloys (Co):

Ni based superalloys are considered to have more strength than the Co based superalloys, yet, the strength of the later become evident when exposed to high temperatures. Their strength are mainly originated from the distribution regarding refractory metal carbides (combining metal and carbon, for example W and Mo). At high temperatures, materials become obviously limited, thus the components in combustion chamber, when the temperature could be 1100 Celsius, are typically created of Co based alloys [2,3].

3. Nickel-based superalloys (Ni):

The most widely used superalloys are the Ni based ones, as they are considered the most complex and the most utilized for various metallurgists and for the hottest parts. Currently, fifty percent of the engines of highly advanced aircrafts are made of Nickel based superalloys. The main features of Ni as a base for alloys are the ability to be strengthened via various indirect and direct processes, also the high-phase stability regarding the (FCC) Nickel matrix. Furthermore, when alloying via aluminum and/or chromium, the Ni surface stability is easily enhanced. As a result, the cost of some latest superalloys might be five times more than turbine steels of high quality. Nickel based superalloys could be applied for higher fractions of melting temperatures, thus they are needed more than the Fe-Ni based and Co based superalloys at operating temperatures close to materials' melting temperature [2,3].

1.2.2 Applications of Inconel718

The recently studied Inconel718 Ni based superalloy that is considered the latest form of Inconel 718 is continuing to become a material that defense and aerospace defense manufacturing cannot swap for other materials because of the features it has such as low-costs, uncomplicated

machinability and the useful mechanical features. Ni based superalloys are commonly utilized in load bearing structures to the maximum melting temperature $0.7T_m$, or ninety percent of their melting point. Inconel 718 superalloys has various significant applications such as (i) Petrochemical and chemical industry, heat exchangers and nuclear power plants (ii) Equipment for heat treatment (furnace mufflers, fans, baskets, fixtures, trays and conveyor belts) (iii) Reciprocating engines (valve seat inserts, hot plugs, turbo chargers and exhaust valves) (iv) Processing metals (parts of rocket engine, space vehicles aerodynamically heated skin and hot work tools and dies) (v) gas turbines of aircrafts (stack gas re heaters, burner cans, vanes, exhaust systems, combustion chambers, shafts and disks [3,5]. Fig. 1.1 shows some of their application of nickel base super alloy.

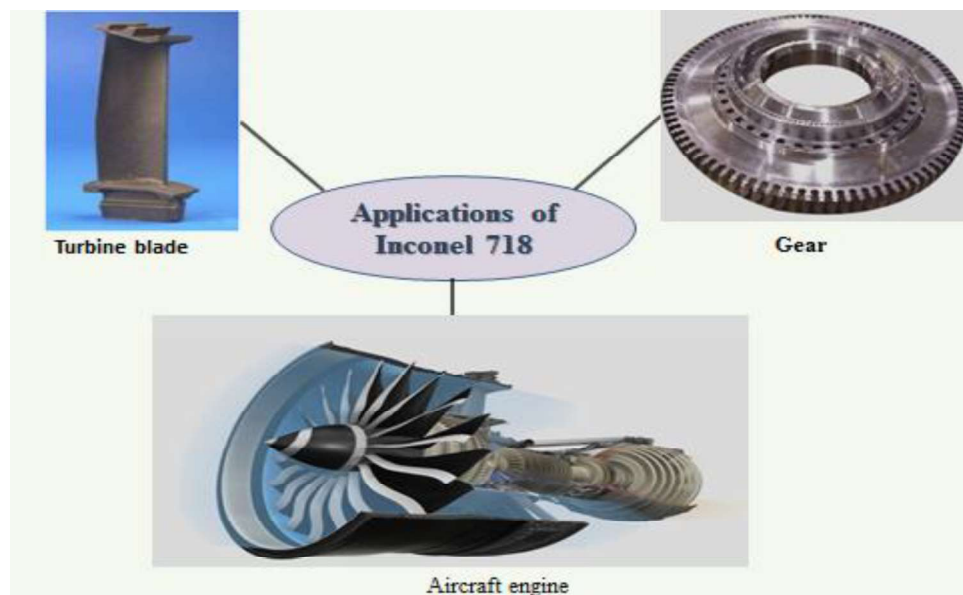

Fig. 1.1 Some applications of nickel base superalloy.

1.3 Machining of Inconel 718

For the purpose of turning the performed metal blocks to the required shape with dimensional accuracy and surface quality, machining is applied as it is one of the highly important methods in the industry. The operation of shaping is performed in the form of metal chips. The machining procedure involves taking away the material from workpiece through a process of

shear deformation by using sharp tool for cutting as well as a motion of workpiece [8]. In the majority of machining procedures, this motion is considered as the primary motion that is referred to as the cutting speed, in this particular case of turning, it might be defined as the velocity of the rotating workpiece. The secondary motion that is referred to as the feed rate, that for turning, it might be defined as the axial distance that the tool advances in single workpiece revolution.[9]

Turning can be defined as a very important machining process with various applications in the industry. Turning was utilized for reducing the diameter via utilizing single point cutting tool that take away the material from surface of the rotating cylindrical workpiece. There are two types of metal turning procedure: the first one is oblique cutting in which the cutting edge makes an inclination angle that is relative to the directions of cutting, whereas the second type is the orthogonal cutting in which the cutting edge of the tools is considered perpendicular to the motion's direction. Orthogonal cutting is rarely not existing in industry; however it is frequently used in studies as a type of explanation related to the procedure of cutting. Fig. 1.2 shows two types of turning process [10].

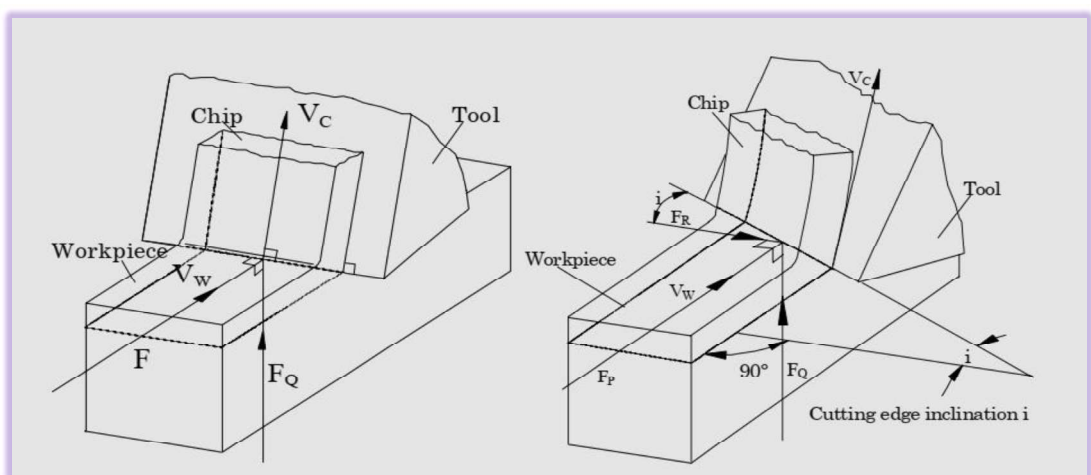

(a) Orthogonal cutting

(b) Oblique cutting

Fig. 1.2 Types of cutting [10]

Superalloys are usually considered to have weak machinability. They are hard to machine because of their top-quality high temperature strength features. The main features that cause the weak machinability of alloys are as follows:

1. High-strength of Ni based superalloys at cutting temperatures causes elevated cutting forces that will generate extra heat at the tool tip compared to the machining of alloy steels.
2. The heat that is produced throughout the machining is transferred to the tool due to the low-thermal conductivity of these alloys, subsequently increasing tool tip temperatures and causing excessive tool wear, which can limit cutting speed and reduce the tool life.
3. Severe abrasive wear will take place at the tool tip because of the existence of abrasive, hard intermetallic compounds and carbides.
4. The high-capacity for work hardening in Ni based alloys lead to depth of cut notching on the tool that causes burr formation on the workpiece.
5. Chip control geometry is required as the produced chip throughout machining is continuous and tough.

Inconel 718 alloy is utilized for parts of high speed airframes and jet engines like (high temperature fasteners and bolts, ring shafts, blades, discs and impellers). Various machining approaches for converting the final engineering product are included in the machinability of these parts as it is shown in Fig. 1.3 for blades, casings and discs [12,13].

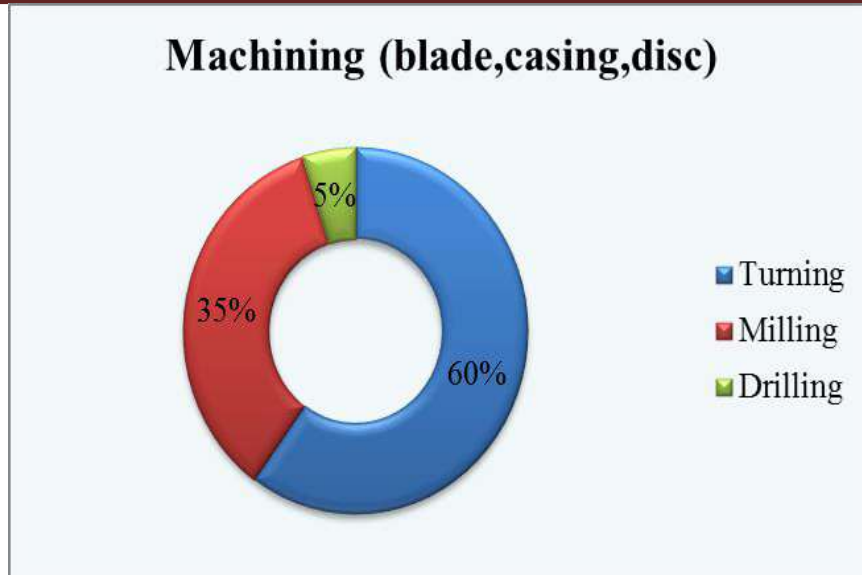

Fig. 1.3 Machining methods for conversion of final engineering products

1.4 Surface Integrity

Surface integrity, including residual stress, micro-hardness and surface roughness are major parameters of the machined part. The surface integrity of the final product is straightly related to the machining parameters. Surface integrity can be defined as a method for measuring the excellence of the machined surface which defines the actual structure of the sub-surface and surface of the workpiece. Serious drawbacks are formed via stress corrosion cracking, creep and fatigue starting at the components' surface. Superior excellent integrity regarding the machined surface helps achieving resistance to failure and high-reliability of components in different engineering applications. According to the surface integrity regarding the machined surface, the material's machinability as technological feature might be quantified [14,15].

1.4.1 Residual Stresses:

Residual stress can be defined as the secondary stress which remains after removing all loads. Depending on its type, the effect of the residual stresses might be useful or damaging to some parts. Typically, the

compressive residual stress have the ability to enhance the quality of machined parts, whereas the tensile residual stress could lead to damage to components. Mostly, all machined components have compressive or tensile residual stress, also both of them might be detected in turning components [16-18].

Residual stresses have a major effect on the operation of machined parts. Components distortion, fatigue effect and corrosion resistance are the characteristics of parts which are impacted via the residual stress. The residual stress could weaken or improve the functional performance of machined parts. As a result, recognizing the residual stress specified via the machining procedure is considered highly important for grasping the ideal of machining as well as the general quality of parts [11,19].

Since the 1950's, the machining process induced residual stress estimated is a topic of study. Study attempts involved experimental outcomes, finite element modeling, systematic modeling, in addition to different combinations of these attempts. Even with the fact that this has been studied effectively, yet, chances for progressing predictive residual stress approaches still exists. The modeling methods have been beneficial to a variety of machining operations such as turning, milling and orthogonal cutting [11]. It is important to keep in mind that residual stresses are not directly measurable; instead the stress determination require a measurement of intrinsic properties, like displacement, elastic strain as well as few secondary quantities, like the sound speed, or magnetic signature which could be associated to the stress [18-20]

Residual stress measurement methods could be classified as destructive, semi-destructive and nondestructive methods [18,21].

Fig. 1.4 shows the techniques of measurement for residual stresses .

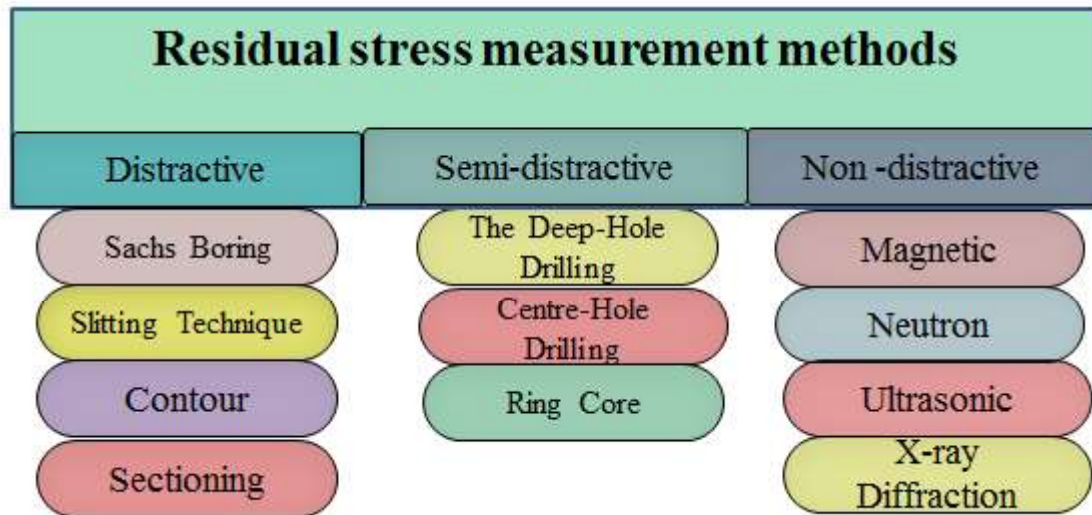

Fig. 1.4 Classifications of Residual Stresses Techniques .

The main goal of the search is the optimization of residual stress for machining process of the Inconel 718. Under this approach, the residual stress must not be considered as a parameter that only depends on the material turning processing parameter's, but must also be considered as a parameter that can be optimized.

1.4.2 Surface Roughness

The surface roughness can be defined as significant measurement of product quality because it impacts the costs of production as well as the effectiveness of mechanical parts. Some mechanical features such as creep life, cracks, fatigue behaviour and corrosion resistance are directly affected by the surface roughness also it affects more functional characteristics of parts such as electrical connectivity, lubrication, wear, light reflection heat transmission and friction. Surface roughness can be considered as a measurement of the surface finish of products and an index of the product [14,15]. There are number of elements affects the workpieces roughness including:

1. Cutting parameters: a) Cutting speed (v). b) Feed rate (f). c) Depth of cut(d).

2. The tool geometry: a) Nose radius. b) Rake angle. c) Side cutting edge angle. d) Cutting edge
3. Workpiece and tool material combination and their mechanical properties.
4. Auxiliary tooling, and lubricant used.
5. Vibrations between the workpiece, machine tool and cutting tool.

1.4.3. Hardness

Hardness might be defined as the material's resistance to the plastic deformation occurring through a process of indentation. The surface microhardness of the workpiece following operation via turning is considered as one of the main factors in surface integrity. One of the most significant parameters of surface integrity is the micro-hardness, it is utilized for finding the component's functional behavior and it could impact their lifespans. The high microhardness of materials and poor machinability of metals result in premature and severe cutting tool wear in dry turning procedure. The microhardness measurements have been applied for identifying the metallurgical changes of the workpiece in all the regions and layers below the machined surfaces following the machining procedure [22]. Microhardness measurements are utilized for measuring the degree of work hardening, sub surface alteration, also they are considered of high importance in determining fatigue crack initiation, wear resistance and corrosion resistance [23].

1.5 Corrosion

Every year a lot of money is spent for repairs of engine, blade and shaft, due to the corrosion damage. In addition to the direct economic losses, the failure of costly infrastructures can be tragedies and can have serious economic, environmental and social penalties. The early detection of part corrosion will lead to suitable actions for delaying or preventing the

damage which could be made via the corrosion. Expanse of labour and money might be saved in post repair works, and possible severe accidents might be avoided the corrosion [24,25].

As regard to the nonmetallic materials, the expression corrosion is always denoting their deterioration from chemical reasons, however, the same may not be applied to metals. Various establishments believe that the expression (metallic corrosion) involves all the interactions of alloys or metals with its environment, regardless of whether it is beneficial or deliberate, deleterious or adventitious.[26]. On this basis, there are different types of corrosion a metal. The corrosion forms can be defined in the following subsection:

1.5.1. Corrosion Types:

(Cavitation corrosion, Selective attack, selective leaching, Stress corrosion cracking, Crevice corrosion, Corrosion fatigue, Intergranular corrosion, Galvanic corrosion, Erosion corrosion, Uniform corrosion, Fretting corrosion, Thermogalvanic corrosion, Pitting corrosion) different corrosion's forms are illustrated in the Fig. 1.5 [26]:

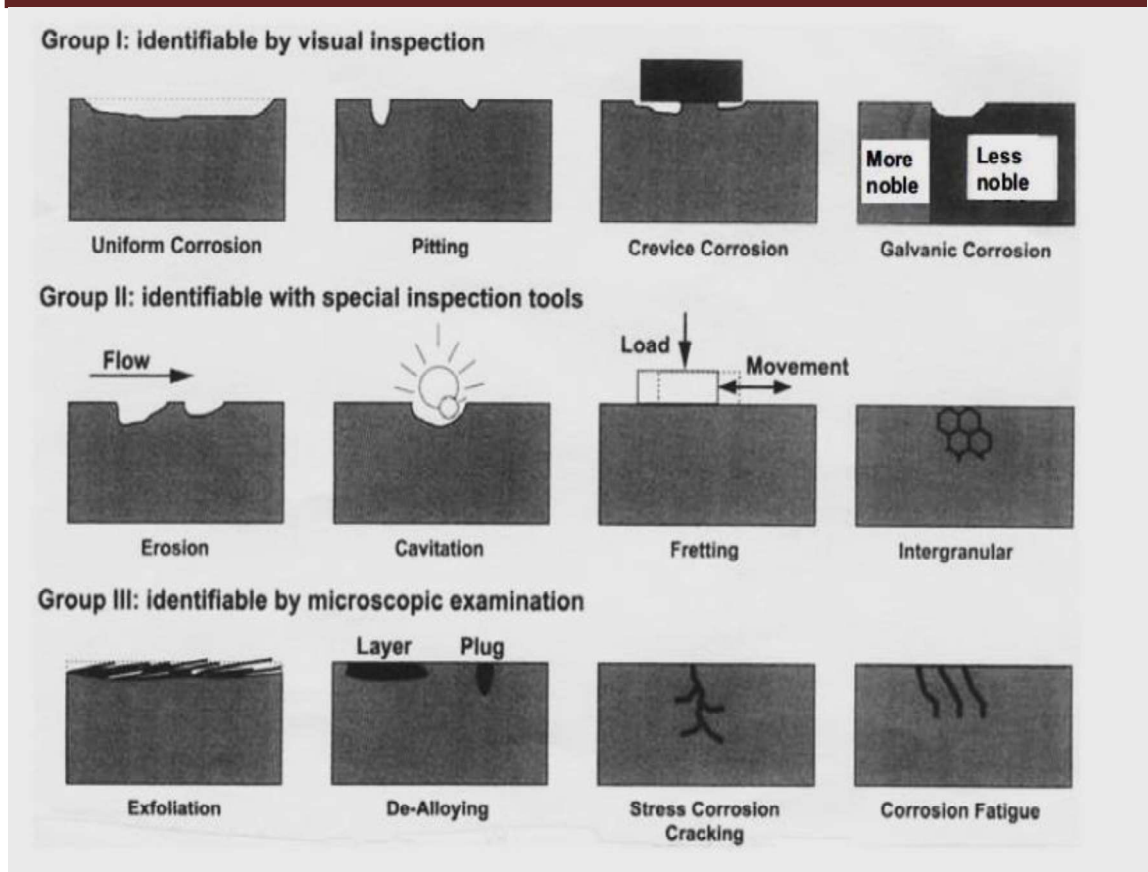

Fig. 1.5 Based on their simplicity of recognition, the major corrosion forms are grouped [26]

1.5.2 Corrosion of Ni-based Superalloy

Because of their excellent mechanical features and their high corrosion resistance, Ni based alloys are considered highly important. Various industrial application are taking advantage of these features, examples of these applications are paper industry, power generation systems, gas and oil extraction, pollution control and petrochemical and chemical processing. Globally, the corrosion resistant of Inconel 718 is highly significant industrial material. In most unfavorable situations, it represents an important upgrade over stainless steels, also its greater initial costs are equalized through its longevity, thus decreased downtime of equipment, it is simple to form and weld to complex industrial components.[27-30]

1.6 Problem Statement

In this study, the focus is on major parameters effect on surface integrity, study roughness ,microhardness ,residual stress ,and corrosion behavior not just study but find optimal parameters produce optimal value to thus response by using Design of Experimental(DOE). DOE Taguchi method is utilized to investigate the impact of the main cutting parameters.

The optimal cutting parameters will be productive for various industries and researchers working in machining process and reduce cost and material. Finite element method offers ways for studying the complex machining procedure at low cost and short time as compared to experimental studies. Corrosion in superalloy and specially in Inconel 718 is very important in industrial field .So to understand the electrochemical behavior of the samples by calculation corrosion rate for alloy by electrochemical potential method under different cutting parameters then select optimal cutting conditions..

1.7. The aim of the study:

In this study an attempt has been made to obtain the following objectives:

1. Determining the effect of different cutting parameters(cutting speed, feed rate and depth of cut) on surface roughness and microhardness throughout turning of difficult to machine Inconel 718 alloy.
2. Determining the effect of machining parameters on residual stresses on the workpiece experimentally and by using finite element simulation (Abaqus software).
3. Finding out temperature distribution on workpiece using finite element simulation and determine the effect of machining parameters on temperature using Taguchi analysis.
4. Investigating the corrosion behavior of machined superalloy after turning and choose optimal machining parameters to avoid corrosion.

5. Improving the application of machining and enable manufacturers to make educated decision by using the optimization of the machining parameters using Taguchi design mixed orthogonal array.

1.8. Study Organization

In-depth research contents are suggested in the form of present study and ordered into the below-mentioned five chapters:

Chapter One – General Introduction

Initial background concerning superalloy, Chemical composition and classification of superalloy also focused and explain corrosion in superalloy. Then explain the difficulty in machining of superalloy ,type of turning and surface integrity including (residual stresses, roughness and micro hardness). The precise purpose of the current search work were presented and the advantages which might be obtained from the current research work were listed.

Chapter Two- Literature Review

Former studies associated to response variables including the residual stress, temperature distribution, surface roughness, microhardness after turning and corrosion in superalloy are present. The research gaps according to the literature have been recognized at the last part of this chapter.

Chapter Three- Methodology and Experimental Work

The features of workpiece ,cutting tool, toolholder and its dimensions with designation have been described. The surface roughness ,microhardness, residual stresses and corrosion rate theory and equations explained in this chapter. All measurement device (roughness, microhardness, residual stresses, corrosion rate) are described with it limitation and manufacturing .The selection of cutting parameters during turning are explained. Simulation section contain step by step 3D dynamic explicit turning model

based on FEM explain residual stress and temperature distributions in workpiece. A brief discussion pertaining to the design of experimental (DOE) with Taguchi method L_9 design is also presented.

Chapter Four- Results and Discussions

Concerning this chapter, the effect of cutting parameters on residual stress and corrosion rate after turning based on analysis of ANOVA are discussed. In addition, surface integrity (surface roughness, microhardness) was evaluated. From FEM ABAQUS program the residual stresses and temperature distribution values comparing with the same experimental values. Lastly, optimization regarding all response variables is achieved through desirability function.

Chapter Five- Conclusions and Suggestions for Future Work

Concerning this chapter, a listing has been made for the conclusions of various studies covered in the search and recommendations for future works in accordance with the limitations of the current study.